

MAINTENANCE

The maintenance must be performed by an authorized person and includes the service schedule of the device itself and the included in it fire detector and remote indicator in accordance with their instruction manuals. Additional cleaning the body of the duct detector is required.

CONDITIONS OF STORAGE, OPERATION AND TRANSPORT

1. Storage
 - o Indoor compartments
 - o Storage Temperature Range - from minus 10 °C to plus 40 °C
 - o Storage Relative Humidity - up to 65 %
2. Operation
 - o Enclosed spaces where there are no aggressive fumes
 - o Operating Temperature Range - from minus 10 °C to plus 55 °C
 - o Operating Humidity Range - from 20% to 90% at 40 °C
3. Transportation

Product has to be transported in closed vehicles in factory packaging.

WARRANTY

The warranty period is 18 months from the date of sale providing .
The manufacturer guarantees the normal operation of the device providing that the installation requirements from this Instructional manual have been observed. Manufacturing company bears no warranty liabilities for damages caused by mechanical damage, improper use of the device or amendments and modifications made after production. The manufacturer carries a warranty liability only for damages caused by company's negligence or fault .

UniPOS

47, "San Stefano" Str., 5800 Pleven, BULGARIA
phone +359 64 891111, +359 64 891 100, fax +359 64 891 110
e-mail: office_pleven@unipos-bg.com

Mladost 1, bl.79B, entr.2, ap.17, 1784 Sofia, BULGARIA
phone/fax +359 2 9744469, +359 2 9743925
e-mail: office_sofia@unipos-bg.com

www.unipos-bg.com

**DUCT SMOKE DETECTOR
TYPE YKB-02K (YKB-02A)
Instruction Manual 01.10**

GENERAL DESCRIPTION

Duct smoke detector YKB-02 is designed to detect the presence of smoke in airstream of ductwork sections or ventilating compartments by the smoke detector mounted in it.

Depending on the type of the fire detector mounted , the duct smoke detector is produced in two variants - for Conventional Fire Alarm Systems (YKB-02K) and for Addressable Fire Alarm Systems (YKB-02A).

In the device is mounted an optical-smoke fire detector type:
-FD8030 for Conventional Systems
or
-FD7130 for Addressable Systems

In order to control the condition of the integrated fire detector, on the housing of the duct smoke detector is mounted an outboard LED Remote Indicator RI31.

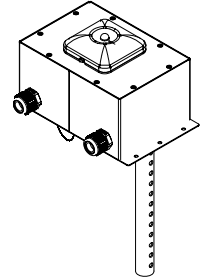

Fig.1

Product design is based on the laws of Aerodynamics.

Part of the air flow runs through the opening holes (pos.7, Fig 4) of the inlet tube (pos.8, Fig.4) and passes through the duct smoke detector as reduces its speed and goes out through the outlet tube (pos.9, Fig 4).The mounted mechanical filters stop the large particles from the airflow and thus they protect the sensitive element of the fire detector from dust contamination.

In case of smoke in the main air conduit, part of this smoke goes through the duct smoke detector and activates the fire detector. The latter sends signal to the Fire Control Panel and the outboard Remote indicator.

TECHNICAL DATA

Speed of the airflow into the air conduit	- 0,5 ÷ 20 m/s
Existence of a mechanical filter of the input and the output	- Yes
Base type of fire mounted detector	- DB8000D (DB7100)
Type of the Fire Detector	- FD8030 (FD7130)
Type of the mounted Remote Indicator	- RI31
Option for installation of different type smoke detectors	- Yes
Dimensions (without the inlet tube , the outlet tube and the nozzles)	(200x120x114)mm
Inlet tube dimensions	ø22 x 200 mm
Outlet tube dimensions	ø22 x 70 mm
Weight	1,3 kg

LABOUR PROTECTION REQUIREMENTS

The personnel authorized to conduct the moutage and the technical service should be aware of the construction of the device its operational mode and the common requirements of workplace security.

Any disassembly of the duct smoke detector from the main air conduit is inadmissible except it is switched off.

Repairing is not allowed while the Fire Control Panel is plugged in the power supply.

INSTALLATION

1. On mechanical and electrical assemblage of the device common instructions for fire detector moutage in firealarm lines (loops) should be followed.

2. There is possibility for the duct smoke detector to be situated on the side, on top, or below the air conduit only in case all the instructions have been observed.

-inlet tube holes (pos.7, Fig.4) are facing the

air flow (pos.11, Fig 4);

-visibility distance of the light-emitting diode(LED) of the Remote Indicator

3. Drill mounting holes on a preliminary specified project location of the air duct according to the dimensions Figure 2.

On the inlet and outlet tubes place rubber sealing washers from the set.

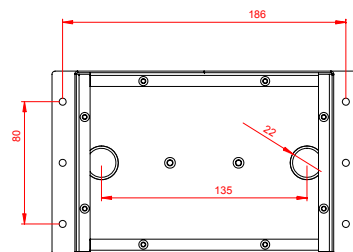

Fig.2

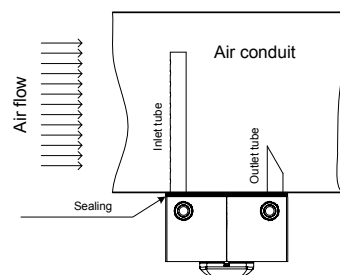

Fig.3

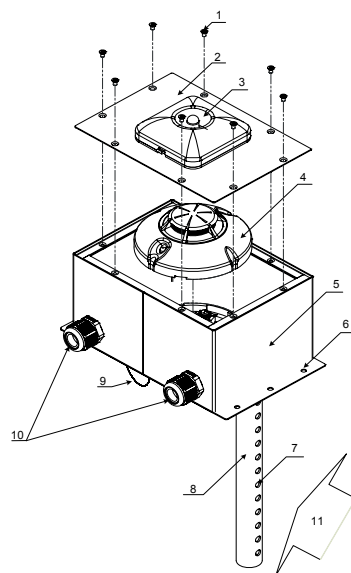

Fig.4

1. Mounting Screw
2. Duct Detector Cover
3. Remote indicator
4. Optical-smoke fire detector
5. Duct Detector Housing
6. Holes for moutage on air conduit
7. Inlet tube holes
8. Inlet tube
9. Outlet tube
10. Nozzles
11. Airflow

4. Mount the device on the air conduit by the six self-tapping screws from the set, and put the duct smoke detector in position so that the inlet tube holes (pos.7, Fig. 4) (poz.8, Fig.4) are upstream (poz.11, Fig.4) the air flow.

5. Unscrew the 8 screws (pos.1, Fig.4) and remove the lid (pos.2, Fig.4) of the body (pos.5, Fig. 4) of the duct smoke detector.

Note: Removing the lid must be made with caution since the Remote indicator (pos.3, Fig.4) is factory built-in together with the fire detector base. Removing the lid provides access to the optical smoke fire detector mounted in the duct smoke detector.

6 Take-off the fire detector (pos.4, Figure 4) from the base.

7. Lead the wires of the fire alarm line (loop) through the input and output nozzles (pos.10, Fig.4) of the duct smoke detector.

8. Connect the wires to the base:
(Remote Indicator RI31 (pos.3, Fig.4) is factory built-in with the detector base)

- for Conventional Control Panel (Fig.5).

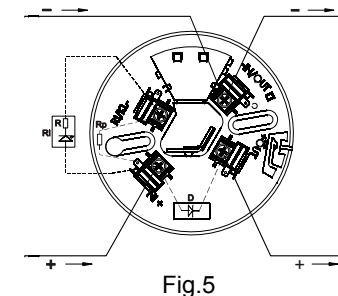

Fig.5

- for Addressable Control Panel (Fig.6)

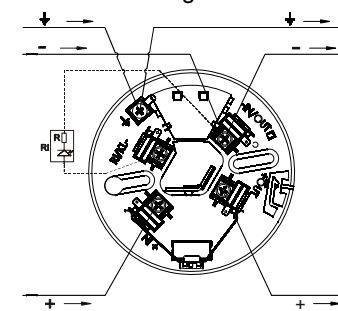

Fig.6

9. Put the fire detector to its base.

10. Place the lid (position2, Figure 4) of the device and bolt up the screws (pos.1, Figure 4).

COMPLEXITY

- Duct Smoke Detector with components assembled: - 1 pc
 - Outboard Remote Indicators RI31;
 - Detector Base DB8000D (DB7100);
 - Optical-smoke fire detector FD 8030 (FD7130)
- Instruction Manual - 1 pc
- Self-tapping screws - 6 pcs
- Sealing - 1 pc
- Transport package - 1 pc